



Europäisches Patentamt
European Patent Office
Office européen des brevets



(11) EP 0 518 250 B1

(12) EUROPEAN PATENT SPECIFICATION

(45) Date of publication and mention
of the grant of the patent:
18.09.1996 Bulletin 1996/38

(51) Int. Cl.⁶: B01D 29/11, B01D 29/96,
B01D 65/10

(21) Application number: 92109644.2

(22) Date of filing: 09.06.1992

(54) Method and apparatus for testing the integrity of filter elements

Verfahren und Vorrichtung zur Integritätsprüfung von Filterelementen

Procédé et dispositif pour tester l'intégrité des éléments filtrants

(84) Designated Contracting States:
ES FR GB IT

(30) Priority: 10.06.1991 DE 4119040

(43) Date of publication of application:
16.12.1992 Bulletin 1992/51

(73) Proprietor: PALL CORPORATION
Glen Cove, New York 11542 (US)

(72) Inventor: Welch, Gerhard
W-6072 Dreieich (DE)

(74) Representative: Geissler, Bernhard, Dr. jur., Dipl.-
Phys. et al
Patent- und Rechtsanwälte
Bardehle . Pagenberg . Dost . Altenburg .
Frohwitter . Geissler & Partner
Postfach 86 06 20
81633 München (DE)

(56) References cited:
EP-A- 0 139 202 WO-A-90/04445
DE-A- 3 805 361 GB-A- 2 132 366

EP 0 518 250 B1

Note: Within nine months from the publication of the mention of the grant of the European patent, any person may give notice to the European Patent Office of opposition to the European patent granted. Notice of opposition shall be filed in a written reasoned statement. It shall not be deemed to have been filed until the opposition fee has been paid. (Art. 99(1) European Patent Convention).

Description

The present invention relates to a method and apparatus for testing the integrity of filter elements in a filter assembly comprising a plurality of filter elements. The invention is particularly applicable to filter systems comprising a very large number of filter elements where the determination of a defective element among so many elements becomes difficult.

Large dimensioned filter systems of various construction are known in which 100 or more filter elements are arranged in one large filter housing. In many applications, for example, in the food and beverage industry or in the pharmaceutical industry, large scale filtration also has to be carried out under sterile conditions. Not only the filter housing but the filter elements along with the filter material must be regularly sterilized. Such sterilization performed for example with hot water or steam can deteriorate the integrity of the filter material, especially when the sterilization has to be carried out frequently.

Deterioration of the filter material and/or other parts of the filter element can also arise in other applications, for example, when chemically aggressive substances or high temperature gases are to be filtered. The deterioration of the filter element can occur in the form of the filter material itself being degraded or a joining of the filter material to the filter housing may become defective and act as a by-pass, i.e. have an opening greater than pore size.

In large filter systems the degradation of one or more individual filter elements can lead to a substantial bacteria contamination of the filtered fluid and possibly the shut-down of the filtration operation. Finding the particular element or elements responsible among the 100 or more elements can be a very time-consuming task, particularly if this is done on a trial and error basis. Means of locating the defective elements in a systematic way are needed.

In GB-A-2 132 366 a method and device for testing the permeability of membrane filters is described. Permeability, bubble point and thus pore size, of a membrane filter is determined exclusively by measurements performed on the inlet side of said membrane filter. Such measurement is performed by measuring the variation with time of pressure within a closed volume with respect to a reference pressure system or by measuring the quantity of gas per unit of time flowing with respect to a reference pressure system or else by measuring said pressure variation twice and draining during the second measurement a predetermined quantity of gas from the space being tested. The essential advantage of the method described in GB-A-2 132 366 consists in the fact that measurements can be made on the inlet side of the membrane filters so that the measuring procedure per se will not contaminate a sterile filter. Moreover, the method for testing the permeability of membrane filters in GB-A-2 132 366 uses a wetted membrane filter.

In DE-A-38 05 361 an integral filter having a permeable tubular shell consisting of several tubular filter elements having different filter properties is described. In the introductory part of the specification it is stated that one result of filter assemblies with a plurality of filter elements is that deviations from said point flow are of the same order of magnitude, whether caused by a defective filter element or by other influence factors.

The object of the present invention is therefore to provide a method of testing the integrity of a large number of filter elements and a filter assembly for carrying out the method by which damaged filter elements can be isolated in a rapid, systematic and efficient manner.

In accordance with the present invention a method of testing the integrity of filament elements is provided as defined in the claims. A plurality of filter elements to be tested, preferably following a sterilization procedure, are wetted (preferably with water). The filter elements with wetted filter material are then subjected to a gas pressure, preferably air pressure, and the resulting gas flow rate collectively through all of the filter elements is measured. By comparing the measured flow rate with a first desired flow rate, the integrity of the filter elements of the entire assembly can be determined. This is accomplished by calculating the amount of deviation between the measured air flow rate and the first desired flow rate. If the deviation falls within a first preset range, this is an indication that all of the elements are intact.

In a preferred embodiment, when the measured gas flow rate exceeds the first desired flow rate by an amount outside of the preset range, this is an indication that at least one of the filter elements is defective. In this embodiment, gas passage through a first section containing only a portion of the plurality of filter elements is then closed off. The flow rate through the remaining filter elements is measured and compared with a second desired flow rate corresponding to the resulting reduced number of filter elements. When this comparison shows that the measured flow rate is within a second preset range, this indicates that the reduced number of filter elements are intact, while the sought after defective element or elements are located in the first section of elements which were closed off in the test.

If however, the defective element or elements are not found in this first section of closed off elements, the above procedure is repeated by successively closing the gas passage in further sections until that section is found which has the defective element or elements. The test procedure has the advantage that individual sections of a large number of filter elements can be checked in a systematic manner. Once the defective section is isolated, the individual elements of this section being of smaller number can be tested rapidly.

According to the present invention a filter assembly is also provided for carrying out the above method as defined in the claims. The filter assembly comprises a plurality of filter elements, where the elements are subdivided into a plurality of sections, each containing a

portion of the filter elements. Each section is provided with an outlet header connected to the individual outlet openings of each of the filter elements in its section. The assembly further comprises valve means arranged in an outlet conduit connected to each of the outlet headers. With these valve means gas flow can be closed off to any particular section during the test procedure. This arrangement allows the isolation of individual groups of elements, which is an enormous time-saving advantage in locating individual damaged elements.

In a further embodiment, the plurality of filter elements are arranged in a common vessel containing the fluid to be filtered, where each filter element has a filter material surface which is in direct contact with the influent fluid. This arrangement of the filters provides that the gas pressure applied during the integrity test to the filter inlet surface is the same for all filter elements.

In a further embodiment it has been found that the sections of filter elements should preferably comprise 2 to 15 filter elements, more preferably 3 to 7 filter elements.

Further objects and advantages of the present invention will become apparent through the following description of preferred embodiments in conjunction with the drawing.

Fig. 1 shows a preferred embodiment of the filter assembly according to the present invention.

Figs. 2a to 2d show a further embodiment of the filter assembly according to the present invention.

Turning to Fig. 1, a filter assembly in accordance with one embodiment of the present invention is shown. A plurality of filter elements 1 are arranged in a housing shown in the form of a large vessel 6. An inlet conduit 8 communicates with the inner volume of the vessel 6. After passing the filter elements 1, the filtrate leaves the vessel 6 through the conduits 5. Outlet conduit 7 collects the outgoing filtrate. The basic elements of the filter assembly described above are shown in Fig. 2 in another embodiment, where the inlet and outlet of the fluid to be filtered is located below the vessel 6 containing the filter elements 1.

The filter assembly in accordance with the invention further comprises an outlet header 2 which is connected to the individual outlet openings 3 of the filter elements 1. The filter elements are divided into a number of sections 10 each having one outlet header 2. Only one section is illustrated in Fig. 1. In the embodiment of Fig. 2, six sections of filter elements are illustrated, as best seen in Fig. 2c. The filter assembly further comprises valve means 4 located in the outlet conduits 5, which are connected to each of the outlet headers 2.

The valve means can be any suitable type of valve, preferably valves which can be employed in a computer-controller automated system. Such valves include ball valves, clack valves or membrane valves. The headers or adapters 2 are designed to connect to the outlet openings 3 of a predetermined number of filter elements 1. In this arrangement, gas flow through all of the elements 1 in the section 10 can be controlled by the

single valve 4 in the outlet conduit 5. Several sections 10 of the filter elements can also be closed off simultaneously. The filter elements in such filter systems are generally of cylindrical form, whereby the outer portion of the cylinder is made up of the filter material. As shown in Fig. 1, the outer surface 9 of the filter material is in direct contact with the interior of the vessel 6. The filter elements can be mounted onto the outlet header 2 in any convenient manner. The outlet header is preferably formed of a synthetic material, PVDF is particularly preferred.

The filter assembly of the present invention is suited for applications in industry where the filter elements may be damaged through purification, decontamination or sterilization procedures which are necessary for reasons of product quality. For example in the beverage industry absolutely sterile conditions are required. After a production time, i.e. filtration operation time, of one or more days, such systems must be evacuated and subjected to a sterilization treatment. The filter elements may be damaged due to the high temperatures and pressures used in sterilization, which is normally carried out with steam and/or hot water. If the filter elements do not withstand such treatment or their material structure is altered, the specified and validated removal efficiency is no longer available when the normal production operation of the system is restarted.

According to the present invention, the integrity of the filter elements can be tested at this point, i.e. before restart of the filter operation. According to the present method, the integrity of the filter elements is tested making use of a filter assembly sub-divided into a plurality of sections as described above. The test is based on the gas diffusion and bulk flow through liquid wetted filter elements. One important application of this method is sterile filter operations where microorganisms should be retained by the filter material. In this case, the pore size of the filter material must remain correspondingly small, in other words the sterilization treatment should not enlarge the pore sizes to the extent that microorganisms could pass the filter material.

The integrity of the elements is determined by first wetting the filter material, preferably with water for hydrophilic membranes. If the filter material is hydrophobic, the wetting agent is preferably a solvent or alcohol or a liquid mixture of low surface tension. Wetting can be performed by filling the vessel 6 with the wetting agent through an inlet connection 11, followed by draining the vessel through an outlet connection 12. The wetting agent is selected depending on the filtration problem and the correspondingly selected filter material.

After wetting, the filter elements are subjected to a fluid pressure. The test fluid can be supplied through the conduit 13 of Fig. 1. Depending on the application, the fluid can be a gas or a liquid, although a gas is particularly preferred. Suitable gases include air or nitrogen.

In the present embodiment, air is the preferred gas medium. The gas is supplied to the interior of the vessel

at a pressure in the range of 50 to 6000 mbar. When supplying the gas, the valves 4 in the outlet conduits 5 are held open. The pressure of the supplied gas is preferably maintained at a constant value during the testing procedure.

The resulting gas flow rate through the wetted filter material of all of the plurality of filter elements 1 is then measured by a measuring device (not shown). This measured flow rate is compared with a desired flow rate which corresponds to the situation in which the filters are in their intact condition. This desired flow rate can also be set to account for possible clogging of the filter element through previous use. Other operational parameters, for example the type of filter or how long it has been in operation will also determine this value. If the deviation between the measured flow rate and the first desired flow rate lies within a first preset range, this indicates that all of the filter elements are intact and the integrity test is completed with a positive result.

On the other hand, when the measured gas flow rate exceeds the first desired flow rate by an amount greater than allowed by the first preset control range, the method of testing is continued further to locate the defective elements. In this embodiment, the gas passage is closed by means of the valves 4 through at least one section of the filter elements containing a portion of the plurality of filter elements. As indicated above, either one of the sections 10 or several such sections can be closed off simultaneously by actuation of the individual valves 4, as is best seen in Fig. 2.

Having closed off at least one section, the gas flow rate through the wetted filter material of the remaining filter elements is now measured. This new flow rate is then compared to a second desired flow rate corresponding to the resulting reduced number of filter elements available for gas passage. From this comparison, the deviation is determined and compared with a second preset range, which may also be different from the first preset range depending on the number of filter elements available. When this deviation is within the second preset range, this indicates that the filter elements passed are intact, while the one or more sections of filter elements which have been closed off must contain the defective elements. If the newly measured flow rate, on the other hand, exceeds the second desired flow rate by an amount outside of the allowed range, the steps above are repeated where the gas passage is closed off for successive individual sections or possibly further groups of sections until a single section of filter elements is located having the defective element or elements.

The particular choice of which section or group of sections is closed off first, or what sections at what locations in the vessel are closed off in what sequence will depend on the particular application. This may also depend on the operator of the filtration system who has knowledge of which groups or sections of elements have been operating in the system longer and are more likely to lose their filtration capacity.

After the single section having defective elements is isolated, the individual elements can be examined one by one. It has been found through experimentation that a reliable test of integrity can be performed when up to 40 filter elements are contained in each section. It is presently preferred that each section comprise 2 to 15 filter elements, more preferably 3 to 7 filter elements.

The present method is particularly suitable for sterile filtration systems where the filter material of the filter elements is of the membrane type. Such filter membrane material will present a barrier to bacteria or to micro-organisms possibly contained in the fluid to be filtered. The present method and filter assembly therefore is particularly suited but not limited to application in the beverage and pharmaceutical industries.

It is also contemplated that the entire method be fully automated. The necessary servo-mechanisms for controlling the valves for gas inlet and outlet belong to the filtration system. Means for the measurement of flow rates are well-known in the art. Computational means for performing the comparisons of measured and desired flow rates are also well-known in systems control.

Claims

1. A method of testing the integrity of filter elements in a filter assembly comprising a plurality of filter elements which are sub-divided into a plurality of sections each containing filter elements said method comprising the steps:

a) wetting the filter material of said plurality of filter elements,

b) subjecting the filter elements with wetted filter material to a gas pressure,

c) measuring the bulk gas flow rate through the wetted filter material of all of said plurality of filter elements,

d) determining whether the measured flow rate deviates from a first desired flow rate by an amount within a first preset range, wherein a deviation within said preset range indicates that all filter elements are intact, and if the measured bulk gas flow rate exceeds said first desired flow rate by an amount greater than allowed by said first preset range,

e) closing the gas passage through at least one section of filter elements containing a portion of said plurality of filter elements,

f) measuring the bulk gas flow rate through the wetted filter material of the remaining filter elements, and

g) determining whether the measured flow rate of step f) deviates from a second desired flow rate corresponding to the resulting reduced number of filter elements by an amount within a second preset range,

wherein a deviation within said second preset range indicates that one or more of the filter elements in said at least one section of step e) is not intact, and if the measured bulk gas flow rate of step f) exceeds said second desired flow rate by a amount greater than allowed by said second preset range, the steps e), f) and g) are repeated while closing the gas passage in step e) for other sections of said plurality of filter elements until a deviation is found in step g) indicating a single section of filter elements in which at least one filter element is not intact.

2. Method of one of the preceding claims, wherein said gas pressure is in the range of 50 to 6000 mbar. 20
3. Method of one of the preceding claims, wherein said gas pressure is held at a constant value. 25
4. Method of one of the preceding claims wherein said gas is air.
5. Method of one of the preceding claims wherein said filter elements have been subjected to a sterilization at high temperatures prior to said integrity testing. 30
6. A filter assembly for carrying out the method of one of the claims 1 to 5 comprising: 35
 - a plurality of filter elements (1), where said plurality of filter elements is divided into a plurality of sections (10) each containing a portion of said filter elements, 40
 - an outlet header (2) connected to each one of said plurality of sections (10), said header communicating with the individual outlet openings (3) of the filter elements in said each one section, 45
 - valve means (4) arranged in a outlet conduit (5) connected to each outlet header (2). 50
7. Filter assembly of claim 6, wherein said plurality of filter elements (1) are arranged in a common vessel (6) containing the fluid to be filtered, each filter element having a filter material surface (9) in direct contact with said fluid to be filtered. 55
8. Filter assembly of claim 6 or 7, wherein each said section of filter elements connected to each said

outlet header (2) comprises in the range of 2 to 15 filter elements, in particular in the range of 3 to 7 filter elements.

5 Patentansprüche

1. Verfahren zum Testen des Betriebszustands von Filterelementen einer Filteranordnung, die eine Vielzahl von Filterelementen aufweist, die in eine Vielzahl von Abschnitten unterteilt sind, wobei jeder Filterelemente umfaßt, wobei das Verfahren die Schritte aufweist:

a) Benetzen des Filtermaterials der Vielzahl von Filterelementen,

b) Aussetzen der Filterelemente mit dem benetzten Filtermaterial einem Gasdruck,

c) Messen der großen Gasdurchflußrate durch das benetzte Filtermaterial aller der Vielzahl von Filterelementen,

d) Bestimmen, ob die gemessene Durchflußrate von einer ersten erwünschten Durchflußrate um einen Betrag in einem ersten voreingestellten Bereich abweicht, wobei eine Abweichung in dem voreingestellten Bereich anzeigt, daß alle Filterelemente intakt sind, und

wenn die gemessene gesamte Gasdurchflußrate die erste erwünschte Durchflußrate um einen Betrag übersteigt, der größer ist als der durch den ersten voreingestellten Bereich erlaubte Betrag ist,

e) Sperren des Gasdurchgangs durch mindestens einen Abschnitt von Filterelementen, der einen Teil der Vielzahl von Filterelementen enthält,

f) Messen der gesamten Gasdurchflußrate durch das benetzte Filtermaterial der restlichen Filterelemente, und

g) Bestimmen, ob die in Schritt f) gemessene Durchflußrate von einer zweiten erwünschten Durchflußrate, die der resultierenden verringerten Anzahl von Filterelementen entspricht, um einen Betrag in einem zweiten voreingestellten Bereich abweicht, wobei eine Abweichung in dem zweiten voreingestellten Bereich anzeigt, daß ein Filterelement oder mehrere Filterelemente in dem mindestens einen Abschnitt von Schritt e) nicht intakt ist bzw. sind, und

wenn die gemessene gesamte Gasdurchflußrate von Schritt f) die zweite erwünschte Durchflußrate um einen Betrag übersteigt, der größer als der

- zweite voreingestellte Bereich ist, die Schritte e), f) und g) wiederholt werden, während der Gasdurchgang im Schritt e) für andere Abschnitte der Vielzahl von Filterelementen abgeschnitten wird, bis eine Abweichung im Schritt g) gefunden wird, die einen einzigen Abschnitt von Filterelementen anzeigt, in dem mindestens ein Filterelement nicht intakt ist. 5
2. Verfahren nach einem der vorangehenden Ansprüche, wobei der Gasdruck in dem Bereich von 50 bis 6000 mbar liegt. 10
3. Verfahren nach einem der vorangehenden Ansprüche, wobei der Gasdruck auf einem konstanten Wert gehalten wird. 15
4. Verfahren nach einem der vorangehenden Ansprüche, wobei das Gas Luft ist. 20
5. Verfahren nach einem der vorangehenden Ansprüche, wobei die Filterelemente vor dem Betriebszustandstest einer Sterilisation bei hohen Temperaturen ausgesetzt worden sind. 25
6. Filteranordnung zum Ausführen des Verfahrens nach einem der Ansprüche 1 bis 5, die aufweist:
- eine Vielzahl von Filterelementen (1), wobei die Vielzahl von Filterelementen in eine Vielzahl von Abschnitten (10) aufgeteilt ist, von denen jeder einen Teil der Filterelemente enthält, 30
- ein Auslaßkopfstück (2), die jeweils mit jedem der Abschnitte (10) verbunden sind, wobei die Kopfstücke jeweils mit den einzelnen Auslaßöffnungen (3) der Filterelemente in jedem Abschnitt in Verbindung stehen und eine Ventileinrichtung (4), die in einer Auslaßleitung (5) angeordnet ist, die jeweils mit jedem Auslaßkopfstück (2) verbunden ist. 40
7. Filteranordnung nach Anspruch 6, wobei die Vielzahl von Filterelementen (1) in einem gemeinsamen Gefäß (6) angeordnet ist, das das zu filternde Fluid enthält, wobei jedes Filterelement eine Filtermaterialoberfläche (9) aufweist, die in direktem Kontakt mit dem zu filternden Fluid steht. 45
8. Filteranordnung nach Anspruch 6 oder 7, wobei jeder Abschnitt von Filterelementen, der jeweils mit dem Auslaßkopfstück (2) verbunden ist, 2 bis 15 Filterelemente, und insbesondere 3 bis 7 Filterelemente aufweist. 50

Revendications

1. Procédé de test de l'intégrité d'éléments filtrants d'un ensemble de filtre comportant plusieurs élé-

ments filtrants qui sont subdivisés en plusieurs tronçons, chacun comportant des éléments filtrants, ledit procédé comportant les étapes consistant à :

- a) humidifier le matériau filtrant desdits plusieurs éléments filtrants,
- b) soumettre les éléments filtrants, munis d'un matériau filtrant humidifié à une pression de gaz,
- c) mesurer le débit de gaz important traversant le matériau filtrant humidifié de tous lesdits plusieurs éléments filtrants,
- d) déterminer si le débit mesuré dévie d'un premier débit voulu d'une quantité située dans une première plage préétablie, dans lequel une déviation située dans ladite plage préétablie indique que tous les éléments filtrants sont intacts, et
- si le débit de gaz important mesuré dépasse ledit premier débit voulu d'une quantité plus grande que permise par ladite première plage préétablie,
- e) fermer le passage de gaz traversant au moins un tronçon d'éléments filtrants comportant une partie desdits plusieurs éléments filtrants,
- f) mesurer le débit de gaz important traversant le matériau filtrant humidifié des éléments filtrants restants, et
- g) déterminer si le débit mesuré de l'étape f) dévie d'un second débit voulu correspondant au nombre réduit résultant d'éléments filtrants d'une quantité située dans une seconde plage préétablie,
- dans lequel une déviation dans ladite seconde plage préétablie indique qu'un ou plusieurs des éléments filtrants situés dans ledit au moins un tronçon de l'étape e) n'est pas intact, et si le débit de gaz important mesuré de l'étape f) dépasse ledit second débit voulu d'une quantité plus grande que permise par ladite seconde plage préétablie, les étapes e), f) et g) sont répétées tout en fermant le passage de gaz à l'étape e) d'autres tronçons desdits plusieurs éléments filtrants jusqu'à ce qu'une déviation soit trouvée à l'étape g) indiquant un tronçon unique d'éléments filtrants dans lequel au moins un élément filtrant n'est pas intact.
2. Procédé selon la revendication 1, dans lequel ladite pression de gaz est située dans la plage allant de 50 à 6000 mbar.
3. Procédé selon l'une quelconque des revendications précédentes, dans lequel ladite pression de gaz est maintenue à une valeur constante.

4. Procédé selon l'une quelconque des revendications précédentes, dans lequel ledit gaz est de l'air.
5. Procédé selon l'une quelconque des revendications précédentes, dans lequel lesdits éléments filtrants ont été soumis à une stérilisation à hautes températures avant ledit test d'intégrité. 5
6. Ensemble de filtre pour mettre en oeuvre le procédé selon l'une quelconque des revendications 1 à 5 comportant : 10
- plusieurs éléments filtrants (1), dans lesquels lesdits plusieurs éléments filtrants sont divisés en plusieurs tronçons (10) comportant chacun une partie desdits éléments filtrants, 15
- un collecteur de sortie (2) relié à chaque tronçon desdits plusieurs tronçons (10), ledit collecteur de sortie communiquant avec les ouvertures de sortie individuelles (3) des éléments filtrants situés dans ledit chaque tronçon, 20
- des moyens formant vanne (4) agencés dans un conduit de sortie (5) reliée à chaque collecteur de sortie (2). 25
7. Ensemble de filtre selon la revendication 6, dans lequel lesdits plusieurs éléments filtrants (1) sont agencés dans un récipient commun (6) comportant le fluide à filtrer, chaque élément filtrant comportant une surface de matériau filtrant (9) en contact direct avec ledit fluide à filtrer. 30
8. Ensemble de filtre selon la revendication 6 ou 7, dans lequel chaque dit tronçon d'éléments filtrants relié à chaque dit collecteur de sortie (2) comporte de 2 à 15 éléments filtrants, en particulier de 3 à 7 éléments filtrants. 35

40

45

50

55

Fig. 1

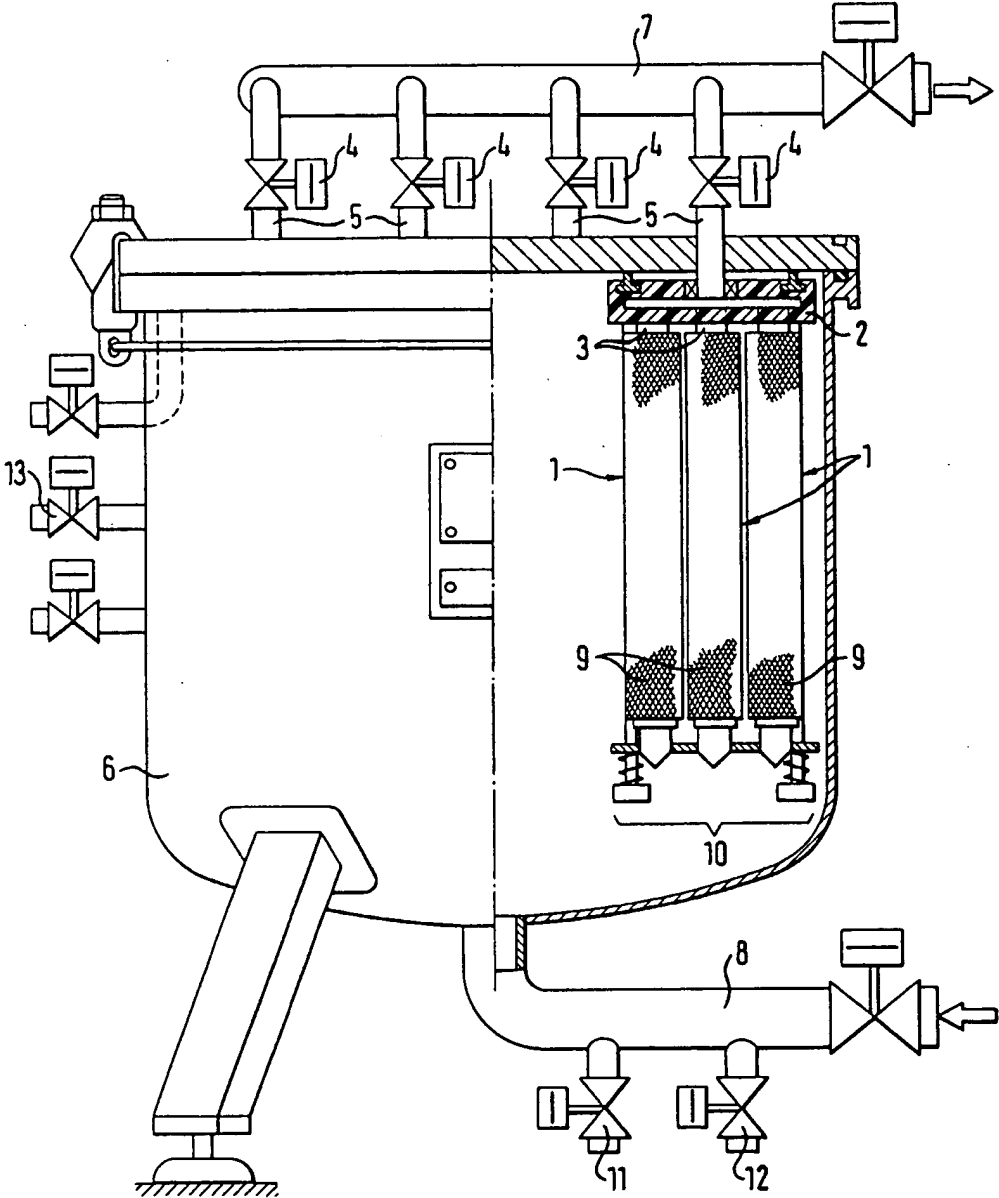

Fig. 2a

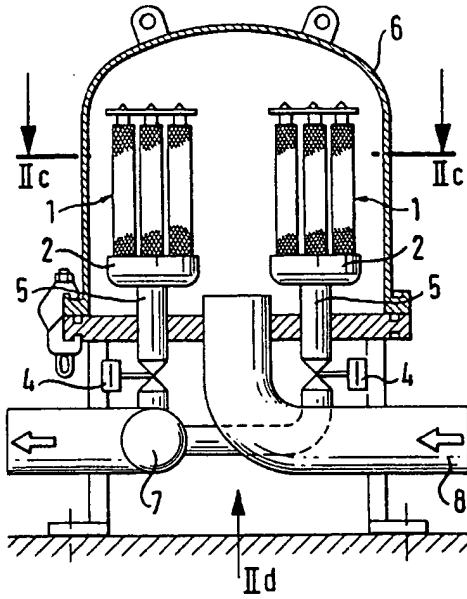

Fig. 2b

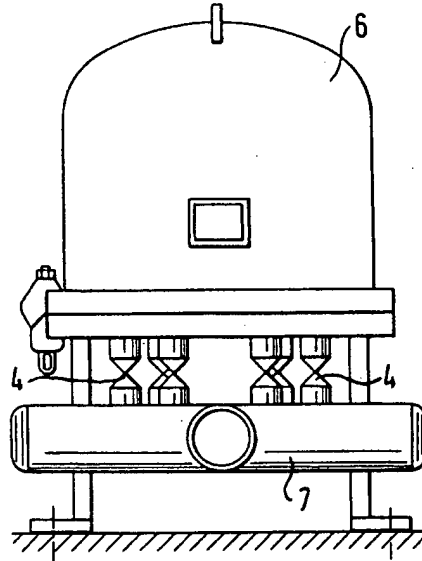

Fig. 2c

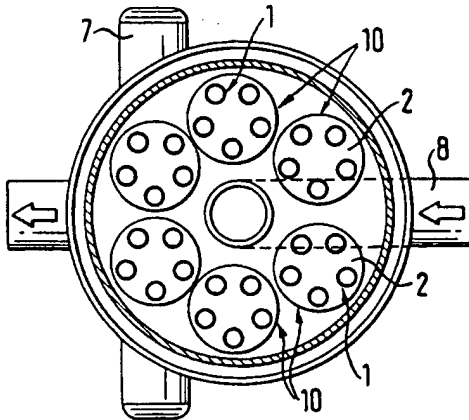

Fig. 2d

